

H G F E D C B A

4

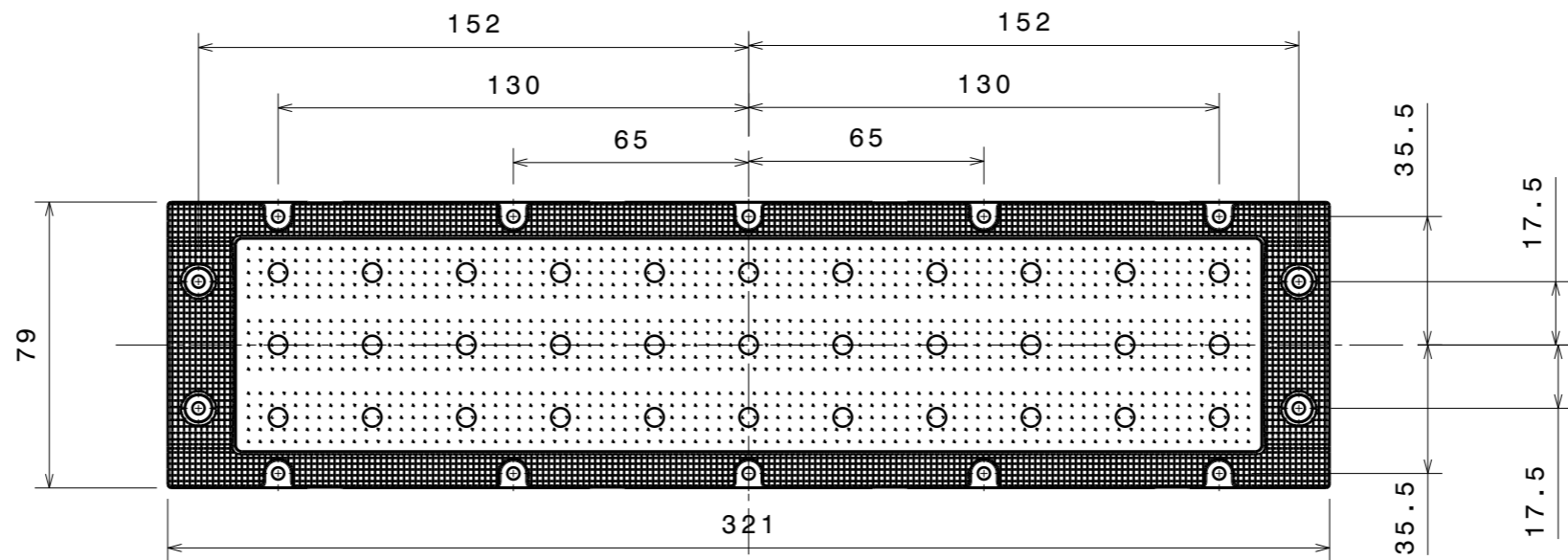

Allowed bending direction

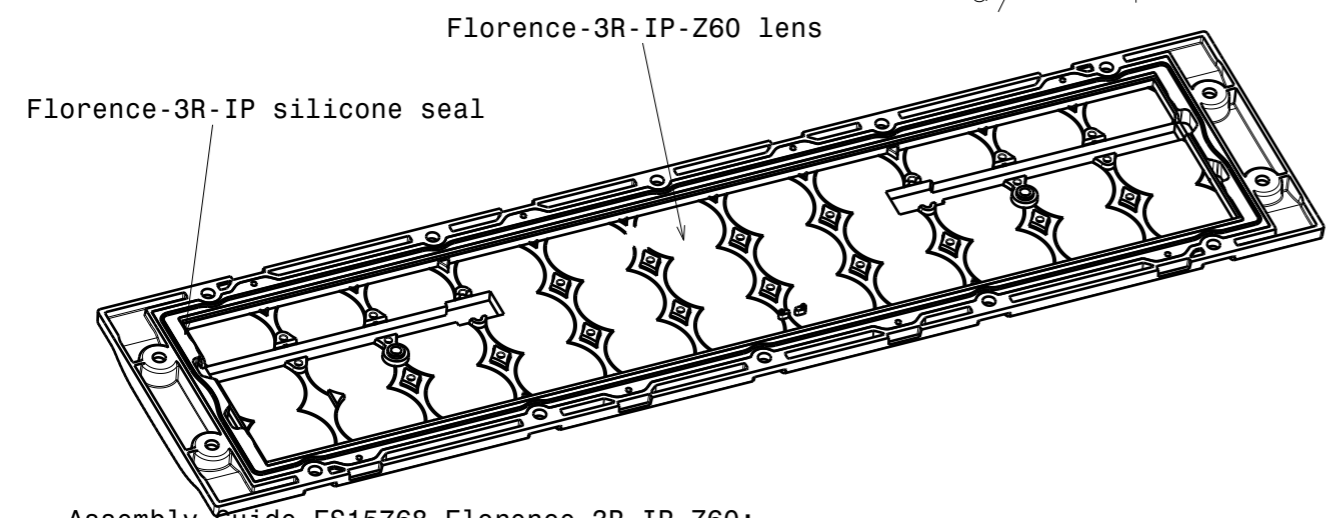
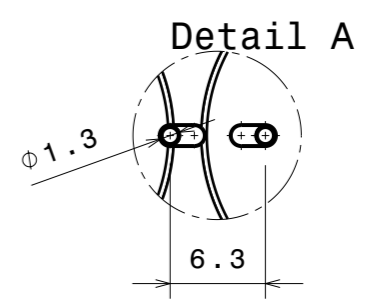
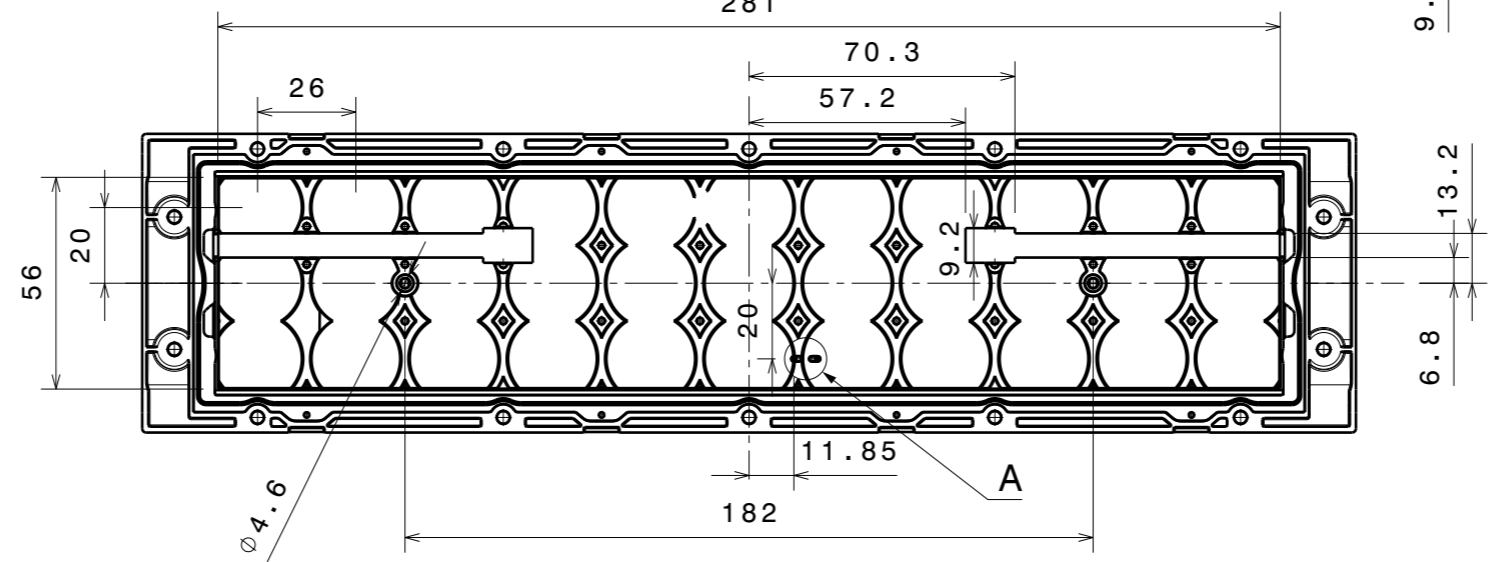
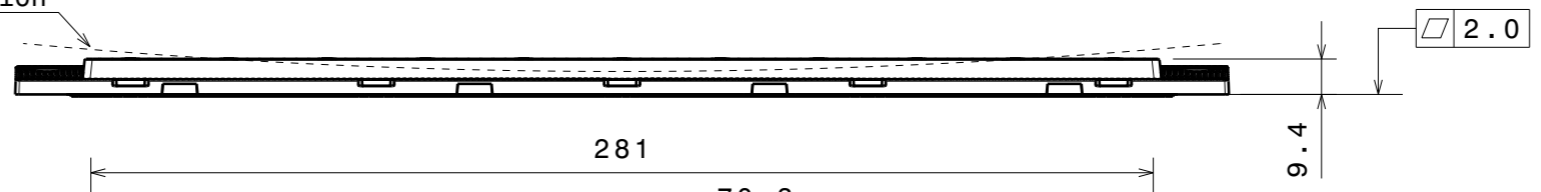

- Assembly Guide FS15768 Florence-3R-IP-Z60:
1. Insert silicone seal into bottom of Florence-3R-IP-Z60 lens
  2. Set lens and silicone seal on top of PCB
  3. Fasten lens to heatsink with 14pcs of M3 screws

Screw type DIN 7985 M3, Max torque 0.6Nm

INDEX	PART NO	DESCRIPTION	MATERIAL	COLOUR
1	F15625	FLORENCE-3R-IP-Seal	Silicone	
2	F15674	FLORENCE-3R-IP-Z60	PC	clear

Tolerances if not otherwise shown  
 According to DIN ISO 2768-1  
 Linear measures:  
 Up to 30mm class M, otherwise class C.  
 According to DIN ISO 2768-2  
 Form and position: class L

**LEDiL** LediL Oy  
 Salorankatu 10  
 FIN 24240 SALO  
 Finland

THIRD ANGLE PROJECTION:

DRAWING TITLE  
 FS15786\_FLORENCE-3R-IP-Z60

This drawing is the property of LEDiL Oy. It may not be reproduced, copied or communicated without a written agreement with LEDiL Oy.

SIZE PART NUMBER  
 A3 FS15786

SCALE 1:2 WEIGHT g SHEET 1/1

H G B A

3

2

1

4

3

2

1